



ND31

POWER NETWORK METER
WITH DATA RECORDING AND MQTT (IIoT),
BACNET/IP OR MODBUS TCP/IP PROTOCOLS

FEATURES

- **Measurement** of 54 power network parameters, including **current and voltage harmonics up to 63rd** in 1-phase 2-wire or 3-phase 3 or 4-wire balanced and unbalanced systems.
- Programmable choice of communication protocols: **MQTT, BACnet / IP lub MODBUS TCP/IP.**
- **High accuracy class (0.2S for active energy).**
- **Graphical color display:** LCD TFT 3,5", 320 x 240 pixels, **fully configurable by a user** (10 screens, 8 parameters in each).
- **Additional 2 screens for harmonics presentation and 1 dedicated page for visualization in the form of an analog meter.**
- Memory of minimum and maximum values.
- 2 configurable alarm outputs.
- Supervisory relay mode for alarm outputs.
- Analog output 0/4...20 mA for retransmission of the measured value and two Pt 100 inputs (eg. for measurement of transformer temperature).
- Archiving of up to 32 measured parameters in the internal memory 8 GB.
- Digital output RS-485 - MODBUS protocol.
- **Modern and user-friendly Ethernet interface 10/100 BASE-T:**
 - protocol: MODBUS TCP/iP, HTTP, FTP,
 - protocol: MQTT,
 - protocol: BACnet/IP,
 - services: www server, ftp server, DHCP client, NTP server.
- Programming of parameters using **free eCon software.**
- Overall dimensions: 96 x 96 x 77 mm.

FEATURES

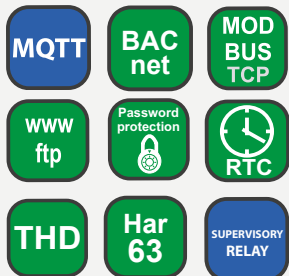

INPUTS

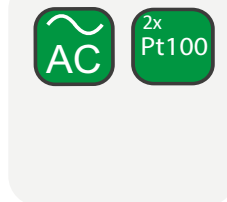

OUTPUTS

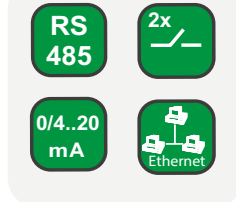

GALVANIC ISOLATION

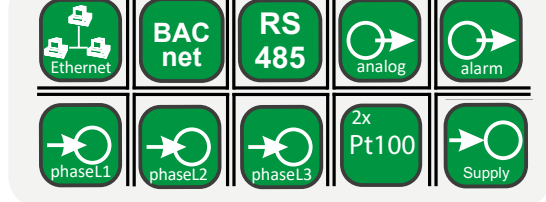

MEASUREMENT AND VISUALIZATION OF POWER NETWORK PARAMETERS

- phase voltages: U_1, U_2, U_3
- phase-to-phase voltages: U_{12}, U_{23}, U_{31}
- phase currents I_1, I_2, I_3
- active phase powers: P_1, P_2, P_3
- reactive phase powers: Q_1, Q_2, Q_3
- apparent phase powers: S_1, S_2, S_3
- active power factors: PF_1, PF_2, PF_3
- reactive/active power factors: $tg\phi_1, tg\phi_2, tg\phi_3$
- active, reactive and apparent 3-phase power: P, Q, S
- mean 3-phase power factors: $PF, tg\phi$
- frequency f
- mean 3-phase voltage: U_s
- mean phase-to-phase voltage: U_{mf}
- mean 3-phase current: I_s
- 15, 30, 60 minutes' mean active power: P_{demand}
- mean apparent power S_{demand}
- average current I_{demand}
- active, reactive and apparent 3-phase energy: EnP, EnQ, EnS
- active, reactive and apparent energy from external counter: $EnPE$
- total harmonic content coefficients for phase voltages and currents $THD_{U1}, THD_{U2}, THD_{U3}, THD_{I1}, THD_{I2}, THD_{I3}$ and for 3-phase voltages and currents THD_U, THD_I
- harmonics for current and phase voltage up to 63rd!
- temperature (2 x Pt100 input)

EXAMPLE OF APPLICATION

MEASUREMENT OF PRODUCTION LINE PARAMETERS.

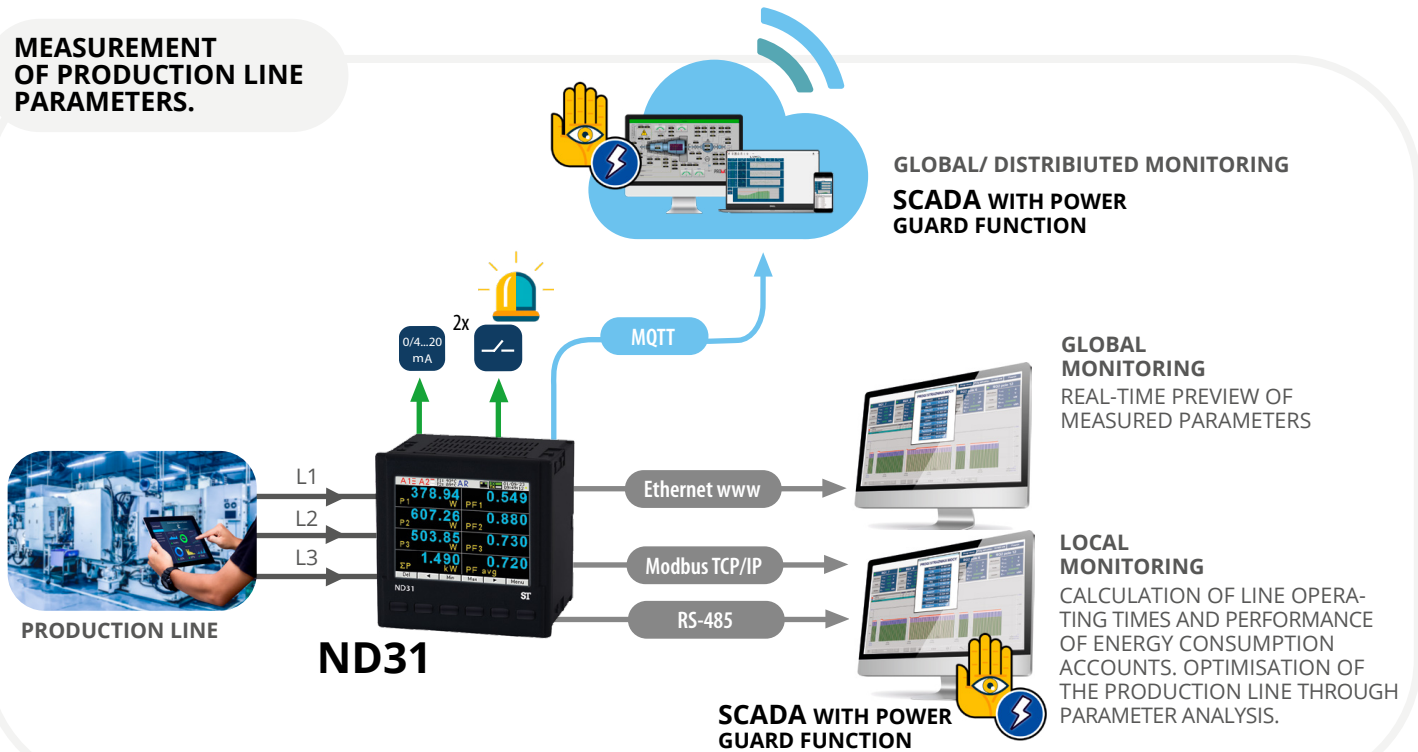

MEASUREMENT OF EQUIPMENT PARAMETERS AND TRANSMISSION TO THE PLC AND VISUALISATION IN SCADA SOFTWARE.

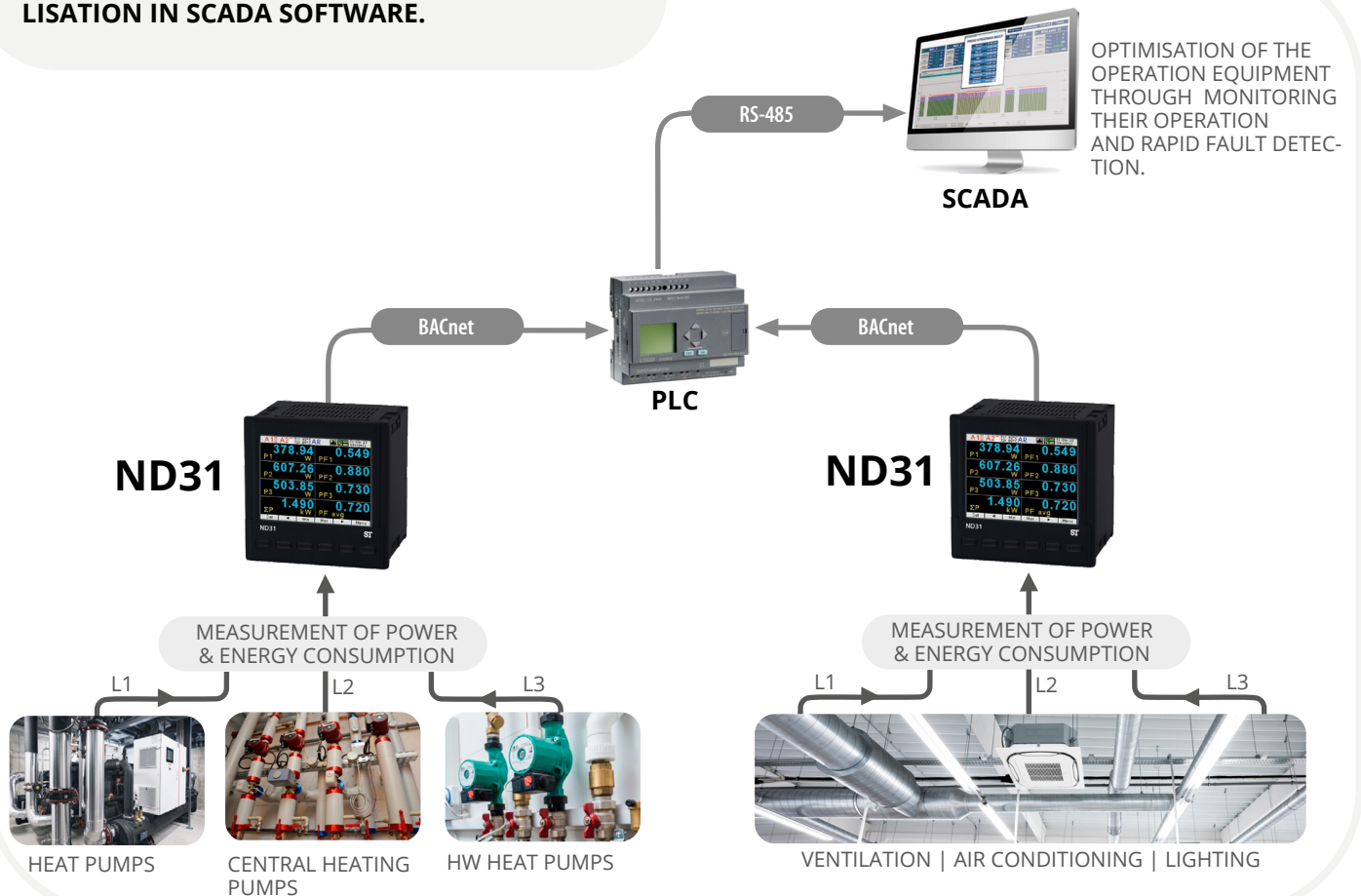

TECHNICAL DATA

MEASURING RANGE

Measured value	Measuring range	L1	L2	L3	Σ	Class
Current I/S A 1 A~ 5 A~	0.002 ..0.100..1.200 A 0.010 ..0.500.. 6.000 A ...100.00 kA (tr_I≠1)	•	•	•		0.2 (EN 61557-12)
Voltage L-N 57.7 V~ 110 V~ 230 V~ 400 V~	5.700..11.500 ..70.000 V 11.000..22.000 ..132.000 V 23.000..46.000 .. 276.000 V 40.000..80.000 .. 480.000 V ...1920.0 kV	•	•	•		0.2 (EN 61557-12)
Voltage L-L 100 V~ 190 V~ 400 V~ 690 V~	10.000 ..20.000..120.000 V 19.000 ..38.000..228.000 V 40.000..80.000 .. 480.000 V 69.000..138.000 .. 830.000 V ...1999.0 kV (tr_U≠1)	•	•	•		0.5 (EN 61557-12)
Active power P	-19999 MW .. 0,000 W19999 MW (tr_U≠1, tr_I≠1)	•	•	•	•	0.5 (EN 61557-12)
Reactive power Q	-19999 MVar .. 0,000 Var19999 MVar (tr_U≠1, tr_I≠1)	•	•	•	•	1 (EN 61557-12)
Apparent power S	0.000 .. 1999,9 VA19999 MVA (tr_U≠1, tr_I≠1)	•	•	•	•	0.5 (EN 61557-12)
Active energy EnP (imported or exported)	0.000 .. 99 999 999.999 kWh				•	0.2S (EN 62053-22)
Reactive energy EnQ (inductive or capacitive)	0.000 .. 99 999 999.999 kWh				•	1 (EN 61557-12)
Apparent energy EnS	0.000 .. 99 999 999.999 kWh				•	0.5 (EN 61557-12)
Active power factor PF	-1.00 ..0 ..1.00	•	•	•	•	1 (EN 61557-12)
Coefficient tg (ratio of reactive power to active power)	-999.99...-1.20 .. 0 .. 1.20...999.99	•	•	•	•	1
Frequency f	45.00...65.000...100.00 Hz				•	0.1 (EN 61557-12)
Total harmonic distortion of voltage THDU and current THDI	0.0 ..100.0 %	•	•	•	•	5 (EN 61557-12)
Amplitudes of the voltage $U_{h2} \dots U_{h63}$ and current $I_{h2} \dots I_{h63}$	0.0 ..100.0 %	•	•	•		II (IEC61000-4-7)

tr_I - Current transformer ratio = Transformer primary current / Current transformer secondary current
tr_U - Voltage transformer ratio = Transformer primary voltage / Voltage transformer secondary voltage

ADDITIONAL INPUTS

Input type	Properties
Input Pt100 (T1, T2)	2 x Pt100, 2-wire, -50...400°C, basic error 0.5 %

DIGITAL INTERFACE

Interface type	Transmission protocol	Remarks
RS-485	Modbus RTU 8N2,8E1,8O1,8N1 Address 1..247	baud rate: 4.8, 9.6, 19.2 38.4, 57.6, 115.2 kbit/s
	Modbus TCP,HTTP,FTP	WWW server, FTP server, DHCP client, NTP server
	MQTT	
Ethernet 10/100 Base-T	BACnet/IP	BACnet Standardized Device Profile (Annex L): BACnet Application Specific Controller (B-ASC); BACnet Interoperability Building Blocks (BIBB) Support (Annex K in BACnet Addendum 135d): DS-RP-B, DS-WP-B, DS-RPM-B, DM-DDB-B, DM-DOB-B, DM-DCC-B, DM-RD-B; Binding methods support: Recive Who-Is, send I-Am (BIBB, DM-DDB-B); Recive Who-Has, send I-Have (BIBB DM-DOB-B)

EXTERNAL FEATURES

Readout field	graphic color display LCD TFT 3,5", 320 x 240 pixels	
Overall dimensions	96 x 96 x 77 mm	mounting hole 92.5 x 92.5 mm
Weight	0.3 kg	
Protection grade	from frontal side: IP65	from terminal side: IP20

RATED OPERATING CONDITIONS

Supply voltage	→ \bigcirc 85...253 V a.c. (40...50...400 Hz), 90...300 V d.c. or 20...40 V a.c., 20...60 V d.c.	power consumption \leq 6 VA
Power consumption	in voltage circuit \leq 0.5 VA	in current circuit \leq 0.1 VA
Input signal	0...0.1...1.2 In; 0.1...0.2...1.2 Un for current, voltage, PF, tgφ,	frequency 45...50...60...100 Hz, sinusoidal (THD \leq 8%)
Power factor	-1...0...1	
Preheating time	5 min.	
Ambient temperature	-10...23...55°C, class K55 acc. to EN61557-12	
Humidity	0...40...60...95%	without condensation
Operating position	any	
External magnetic field	\leq 40...400 A/m d.c.	\leq 3 A/m a.c. 50/60 Hz
Short-term overload	voltage input: 2 Un (5 sec.)	current input 50 A (1 sec.)
Admissible crest factor	current: 2	voltage: 2
Additional error (in % of the intrinsic error)		from ambient temperature change: $<$ 50% / 10°C

SAFETY AND COMPATIBILITY REQUIREMENTS

Electromagnetic compatibility	noise immunity	acc. to EN 61000-6-2, EN IEC 61326-1
	radio-frequency common mode: • level 2: 0,15...1 MHz • level 3: 1 MHz...80 MHz	
Isolation between circuits	noise emissions	acc. to EN 61000-6-4, EN IEC 61326-1
	basic	acc. to EN 61010-1
Pollution level	2	acc. to EN 61010-1
Overvoltage category OVC	III	for voltage to earth up to 300V
	II	for voltage to earth up to 600V
Maximal phase-to-earth voltage	• for supply circuit and relay outputs 300 V • for measuring input 500 V • for circuits of RS-485, Ethernet, analog outputs: 50 V	acc. to EN 61010-1
Altitude a.s.l.	$<$ 2000 m	

CONNECTION DIAGRAMS

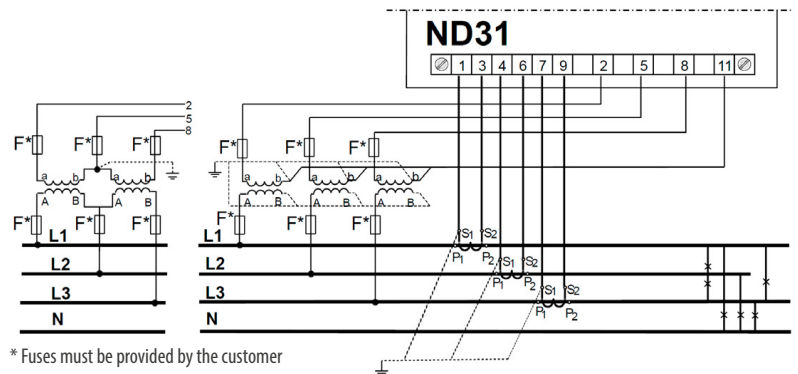
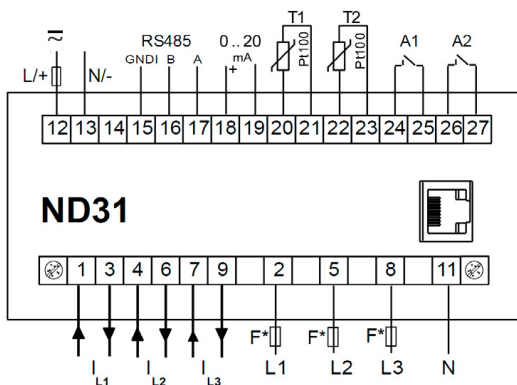

* Fuses must be provided by the customer

* Fuses must be provided by the customer

Description of meter connections strips

Indirect measurement in 4-wire network - connection of input signals

DISPLAING OF MEASUREMENT PARAMETERS



up to 10 programmable screens
(8 parameters per page);
ability to change color for all screens

Available colors for digital indications:

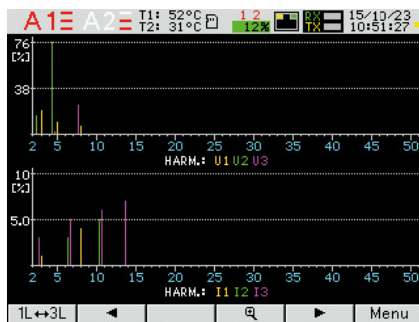
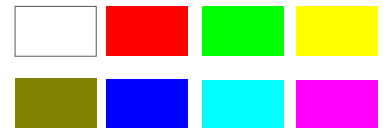

two screens dedicated to harmonics;
indication of individual harmonic
for voltages and currents (up to 51st);
bargraph presentation for all harmonics
with zoom function



presentation in the form of analog
meter view with min/max preview
for display value and zoom function



easy to use and intuitive menu;
information bar with status of: phase
sequence, alarm outputs, temperature
measurements, archiving and memory,
Ethernet and RS-485 interfaces,
time and date

METER CONFIGURATION WITH FREE eCON SOFTWARE

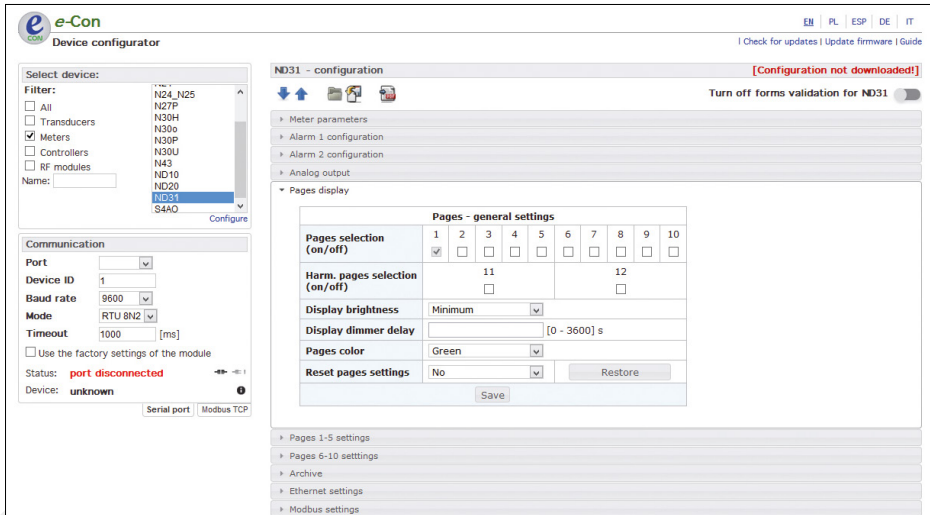

ability to configure and update ND31 with free eCon software (via RS-485 or Ethernet interface)

REMOTE READOUT OF PARAMETERS THROUGH ETHERNET: WWW SERVER, FTP

3-PHASE POWER NETWORK METER TYPE ND31

Page 1				Page 2							
U12	378.040	V	I1	1.005	A	U12	378.040	V	ΣP	843.787	W
U23	383.467	V	I2	2.105	A	U23	383.467	V	ΣQ	725.969	var
U31	392.184	V	I3	1.805	A	U31	392.184	V	ΣS	1125.615	VA
f	49.999	Hz	I avg	1.638	A	U123	384.564	V	PF avg	0.778	
Page 3				Page 4							
ΣP	843.787	W	P DMD	843.795	W	THDU12	43.049	%	THD I1	4.100	%
ΣQ	725.969	var	S DMD	1125.611	VA	THDU23	43.359	%	THD I2	5.784	%
I avg	1.638	A	I DMD	1.638	A	THDU31	22.461	%	THD I3	10.879	%
tg avg	0.810		PF avg	0.778							
Page 5											
ΣP	843.787	W	EnP+	21.661	GWh						
ΣQ	725.969	var	EnP-	2786.344	MWh						
ΣS	1125.615	VA	EnQ L	13.761	Mvarh						
En S	24.854	GVAh	EnQ C	12.036	Mvarh						

WEB server for remote reading of current measurement data; FTP server for downloading archived CSV files

The screenshot shows the ND31 web interface. The top part displays the same parameter readouts as the table above. Below this, there is a 'Harmonics numbers' window. The window title is 'Harmonic U no : H18 U1=0.0 %, U2=0.0 %, U3=0.0 %'. It contains two bar charts. The first chart shows the harmonic spectrum for phase U1, with the highest peak at the 4th harmonic (76.1%). The second chart shows the harmonic spectrum for phase U2, with the highest peak at the 13th harmonic (10.0%). The interface also includes a status bar at the bottom with icons for measurement, help, and Ethernet settings.

ORDERING CODE

Meter ND31	X	2	2	X	X	X	XXXX
Input voltage (phase/phase-to-phase) Un:							
3 x 57.7/ 100 V, 3x 230/ 400 V	1						
3 x 110/ 190 V, 3 x 400/ 690 V	2						
Outputs /inputs:							
2 relays, 1 analog output, 2 inputs PT100		2					
Interface:							
RS-485 and Ethernet, internal memory			2				
Supply:							
85...253 V a.c., 90...300 V d.c.				1			
20...40 V a.c., 20...60 V d.c.				2			
Language:							
Polish/ English					M		
other*					X		
Acceptance tests:							
without additional quality requirements						0	
with an extra quality inspection certificate						1	
with an extra calibration certificate						2	
acc.to customer's request*						X	
Version:							
standard							
custom-made*							XXXX

* only after agreeing with the manufacturer

ORDERING EXAMPLE: The code **ND31 1221M0** means:

- ND31** – ND31 meter,
- 1** – input voltage 3 x 57.7/100 V, 3 x 230/400 V,
- 2** – 2 relays, 1 analog output 0..20 mA, 2 x Pt100 inputs,
- 2** – RS-485 and Ethernet, internal file system memory,
- 1** – supply 85..253 V a.c., 90..300 V d.c.
- M** – polish-english version,
- 0** – without additional quality requirements,
 - standard version.