



## Technical Data Sheet

### *EPSILON Cam TNC Series*



*EPSILON Cam TNC Series* TNC switch is a three position switch , when it is in close position it put the circuit breaker in operation by energizing the closing coil and when it is in trip position it will trip the circuit by energising the trip coil in circuit breaker.

• Epsilon TNC 25 A

• Epsilon TNC 32 A

### Special Features

- Compact Design
- 60 Degree Angle of Throw
- Pistol Grip Handle
- Spring Loaded Mechanism
- Standard Mounting Plate

## Application

TNC switch is a three position switch, when it is in close position it put the circuit breaker in operation by energizing the closing coil and when it is in trip position it will trip the circuit by energising the trip coil in circuit breaker.

The switch return to neutral position after any operation (either close or trip). It makes close & open commands momentarily.

A focused range of Epsilon Cam Spring Return Series switches cover most of applications with different contact designs, contact materials and terminal allow their use as control switches as well as in electronic circuitry and in aggressive environment according to IEC/EN 60947-1, 3 &5

## Operation

TNC (Trip Neutral Close) in normal condition the switch will be in Neutral position. To close the circuit breaker, user need to rotate the switch knob in direction of "Close" as mentioned in TNC switch and breaker will be in operation. We need to rotate the switch knob in the direction of "Trip" as mentioned in TNC switch so that the circuit breaker will get tripped for maintenance.

Normally Open (N.O.) & Normally Close (N.C.) Momentary switches can be described as normally open or normally close, which refers to original or rest position of the switch. Normally open momentary switch has one or more circuits that are open when actuator is at its normal or rest position. An open circuit is an incomplete circuit with open space between contacts. Therefore, N. O. circuit is also referred as "Normally OFF".

Normally close momentary switch has one or more circuits that are close when actuator is at its normal or rest position. A close circuit is a complete circuit with closed contacts. Therefore, N. C. circuit is also referred as "Normally ON".



**Dimensions Details**

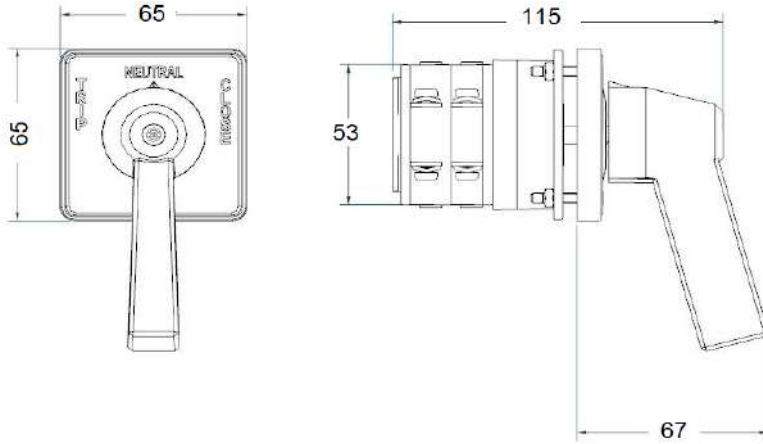

**Panel Mounting**

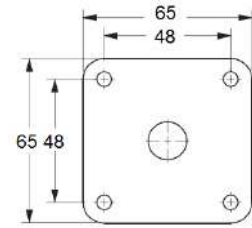

**Technical Data**

Description		Unit	TNC 25	TNC 32
Rated Operational Voltage	Ue	V AC	690	690
		V DC	250	250
Resistance to Surge Voltage	Uimp	kV	6	6
Rated Uninterrupted Current	Ith	A	32	40
<b>Rated Operational Current Pilot Duty AC15</b>		<b>Ie</b>		
220-240 V AC		A	8	14
380-440 V AC		A	5	6
Short Circuit Protection HRC Fuse Size		A	25	32
Rated Short Circuit		KA	10	10
<b>Terminal Cross Section</b>				
Rigid Wire	min	mm <sup>2</sup>	1.5	2.5
	max		4	6
Flexible Wire	min	mm <sup>2</sup>	1	1.5
	max		2.5	4
Terminal Screw			M4	M4
Terminal Tightening Torque			1.2 Nm	1.2 Nm

**General**

**Endurance :**

**Mechanical**

100,000 operations at  
300 cycles/hour

**Electrical**

10,000 operations at  
120 cycles/hour  
Operational Temperature  
25°C to 55°C, frequency  
upto 5 kHz

**DC Breaking Capacity**

Voltage	No. of Contacts in series	TNC 25				TNC 32			
		Resistive Amps	Inductive L/R Amps			Resistive Amps	Inductive L/R Amps		
			10 msec	20 msec	40 msec		10 msec	20 msec	40 msec
50 V	1	20	20	15	6	25	25	18	8
	2	-	-	20	14	-	-	25	18
	3	-	-	-	20	-	-	-	25
125 V	1	3	2.5	1.5	1.0	5	3	2	1.2
	2	20	15	10	5	25	18	12	6
	3	-	20	20	10	-	25	v	12
250 V	1	1.0	0.5	0.3	0.2	1.2	0.6	0.4	0.3
	2	5	2	1.0	1.5	6	2.5	1.2	0.6
	3	20	10	4	1	25	12	5	1.2

**Ordering information**

Product Code	TRCX-	X	X	X	XX	X	X	X	X	0	0ST
	TSR1 : TNC 1NO 1NC Switch										
	TSR2 : TNC 2NO 2NC Switch										
Ampere code for TRCX	25A	A									
	32A	B									
Type for TRCX	1NO 1NC		2								
	2NO 2NC		4								
Poles for TRCX	2 Poles			2							
	4 Poles			4							
No of ways for TRCX	1 Ways				01						
Neutral for TRCX	With NEUTRAL					N					
Angle for TRCX	60 Degree						6				
Knob shape for TRCX	Pistol Shape							L			
Front Plate colour for TRCX	Silver sheet & Black knob								A		
	Yellow sheet & Red knob								B		
Reserved										0	0ST



**sifam tinsley**  
PRECISION INSTRUMENTATION

**Sifam Tinsley Instrumentation Inc.**  
3105, Creekside Village Drive,  
Suite No. 801, Kennesaw,  
GA 30144 (USA)  
**E-mail Id :** psk@sifamtinsley.com  
**Web :** www.sifamtinsley.com  
**Contact No. :** +1 404 736 4903

**Sifam Tinsley Instrumentation Ltd**  
Unit 1 Warner Drive,  
Springwood Industrial Estate  
Braintree, Essex, UK, CM72YW  
**E-mail:** sales@sifamtinsley.com  
**Web:** www.sifamtinsley.com/uk  
**Contact:** +44(0)1803615139